

Operation Manual



*Ex pzc
Purge Gas
Monitoring System
Type A42 System (Zone 2/22)*

Exepd GmbH
i_Park Tauberfranken 23
D-97922 Lauda-Königshofen
Tel.: +49 (0)9343 627055-0
Fax: +49 (0)9343 627055-99
www.exepd.de
Mail: info@exepd.de

Content:

1	General	3
2	Intended Use	4
3	Applied Standards	4
4	Functional Description	5
4.1	Purge Gas Monitoring System for Ex Zone 2 (Explosive Gas)	5
4.2	Purge Gas Monitoring System for Ex Zone 22 (Explosive Dust)	5
5	System Components for Ex Zone 2 and/or 22	6
6	Leo Controller Type A42-M2 with Integrated Control Unit A41-I2.....	8
6.1	Functioning	8
6.2	View	8
6.3	Technical Specifications:	9
6.4	Circuit Diagram.....	10
7	Pressure Switch Type A42-P1 for Ex px Control Cabinets.....	11
7.1	Functioning	11
7.2	View	11
7.3	Technical Specifications	11
8	Purge Valve Type A42-M6 (Digital Technology)	12
8.1	Functioning	12
8.2	View	12
9	Control unit of controller A42-M2.....	13
9.1	BCD switch Program	14
9.2	BCD switch Parameter (Program auf Pos. 0)	14
9.3	BCD switch Parameter (Program on Pos. 1)	14
9.3.1	Switching value of MIN:	14
9.3.2	Switching value of DP.....	14
9.3.3	Switching value of MXP.....	14
9.3.4	Switching value of MAX	15
9.3.5	Purge program	15
9.3.6	Adjustment of the purge time.....	16
9.3.7	Time delay	16
9.3.8	Signal relay.....	17
9.4	Rotary switch "Parameter" (Program on Pos. 3)	17
10	Purge Time Calculations (Ex Zone 2).....	18
11	Operation, Maintenance and Troubleshooting	18
12	Order Numbers.....	19
13	Dimensions:	20
13.1	Controller A42-M2	20
13.2	Pressure monitor A42-P1.....	20
13.3	External control unit	21
13.4	Pressure regulator A42-P6.....	21
14	Test certificate of Leo 2 Controller type A42-M2	22

1 **General**

The products described in this manual (components of the purge gas monitoring system) must be certified and in safe and trouble-free condition when leaving the factory. In order to maintain this condition and to ensure a trouble-free and safe operation of these products they may not be used other than in accordance with the specifications in the present operation manual. Furthermore, safe and trouble-free operation of these products can only be guaranteed if transport and storage are carried out correctly and operation is carried out with due care.

This operation manual contains all information required for the proper usage of the purge gas monitoring system. It is for technically qualified staff only. For safe installation and commissioning the safety instructions and warnings described in this manual must be understood and implemented in a technically correct way. Only qualified staff disposes of the technical knowledge required for interpretation and application of the general safety instructions and warnings provided in these documents.

This operation manual is an integrative part of the delivery scope although separate ordering and delivery is possible due to logistic reasons. Make sure to enclose this operation manual when passing on the Leo purge gas monitoring system.

The structure of all warnings and safety instructions in this operation manual is based on the same principle. A symbol on the left hand side represents the hazard type. On the right you will find a description of the safety hazard and instructions on how to prevent this hazard.



CAUTION:

Information preceded by the word CAUTION indicate hazards that may result in light to medium injuries, damage to property or the environment and explosion hazards.



WARNING:

Information preceded by the word WARNING indicate hazards that may cause severe or deadly injury and acute explosion hazards.



Note:

These notes contain additional information for a favourable usage of the purge gas monitoring system.

In general, our "General terms and conditions" shall apply. These have been at the operator's disposal since conclusion of the contract at the latest. Any warranty and liability claims in respect to personal or property damage will be excluded if caused by one or several of the following:

Improper assembly, commission, operation and maintenance of the components of the purge gas monitoring system.

Ignore the instructions in the operation manual in respect to transport, storage, assembly, commissioning, operation and maintenance.

Emergencies caused by extraneous elements and force majored.

The components of the purge gas monitoring system are covered by a 1 year warranty period starting on the date of delivery. This warranty comprises all parts of the delivery and is restricted to free of charge replacement or repair of the defective parts in our factory. The delivered packaging should be kept for this purpose, if possible. If required, products are to be posted to us after written agreement. Repairs at the customer's site are not possible.

2 Intended Use

The components of the purge gas monitoring system type A42 system are devices fixedly installed for use within Ex zone 2 or 22. The components of the purge gas monitoring system are not suitable for use in zones 0, 1 or 21, 20.



CAUTION:

The purge gas monitoring system may be modified by the user in a way that a purge time is not active. (Use in "Explosive dust systems").

Therefore, check pre-purge time and sequence for "Explosive gas" systems.

The attaching positions are generally subject to the construction or installation instructions of the pressurized control cabinet. The respective installation positions of the components of the purge gas monitoring system are specified in the present operation manual.

Please observe the electrical specifications indicated on the data plate and the device category for the site of operation.

Modifications on the components of the purge gas monitoring system type A4* system are subject to our prior approval.

3 Applied Standards

The following standards concerning explosion protection solutions were applied for evaluation of the purge gas monitoring system A42 system.

EN 60079-0;

EN 60079-2;

EN 60079-11;

EN 60079-31;

EN 60079-15

4 Functional Description

The following functional descriptions basically reflect the functions documented in the corresponding standards.

4.1 Purge Gas Monitoring System for Ex Zone 2 (Explosive Gas)

The ignition protection type **Ex pzc** called: "Pressurized enclosure" is described in DIN EN 60079-2 and is based on the measure that explosive gases existing in a closed control cabinet are purged out followed by generation of a maintained positive pressure with respect to the atmosphere. Due to the higher internal pressure in the enclosure with respect to the atmosphere explosive gases may at no time enter the inside of the control cabinet. This allows the creation of an area without explosive gas mixtures where electrical devices without explosion protection can be mounted and operated.

The applications of the pressurized enclosure are classified as follows:

- 1) Pressurized enclosure with compensation of leakage losses: maintenance of a positive pressure in a control cabinet by feeding purge gas in order to compensate leakage losses of the control cabinet. No combustible measurement gases are introduced in the control cabinet for this purpose.
- 2) Pressurized enclosure with continuous purging: maintenance of a positive pressure in a control cabinet by continuous purging of the control cabinet with purge gas. No combustible measurement gases are introduced in the control cabinet for this purpose.
- 3) "Containment Systems": Pressurized control cabinets with analysis devices for which combustible media are introduced in the control cabinet. Constructional measures cause no or only limited internal releases. A specific pressurized enclosure system is available for the "containment systems" application. The operation manual for this system is prepared separately and is available on request.

The mentioned applications are sub-classified into two operating conditions:

a) Pre-purge stage

In order to prevent explosive atmosphere, which entered during idle times, from becoming a risk the control cabinet must be purged with purge gas (compressed air or inert gas) prior to commissioning. The volume is subject to the test during initial commissioning. Measurement or determination of the flow is effected on the outlet of the pressurized control cabinet.

b) Operation stage

The positive pressure inside the control cabinet with respect to the atmosphere must be maintained during operation. If the internal pressure falls below a determined minimum value the purge gas monitoring system will automatically switch off the entire electrical supply to the pressurized non-explosive devices inside the control cabinet.

4.2 Purge Gas Monitoring System for Ex Zone 22 (Explosive Dust)

The ignition protection type **Ex pcz** called: "Pressurized enclosure" is described in DIN EN 60079-2 and is based on the measure that a positive pressure with respect to the atmosphere is generated and maintained in a closed control cabinet. Due to the higher internal pressure in the control cabinet dusts can enter the inside of the control cabinet at no time. This allows the creation of a dust-free area where non-explosive-proof electrical devices can be mounted and operated. Dust deposits in the inside of the control cabinet must be removed prior to switching on the control cabinet.

5 System Components for Ex Zone 2 and/or 22

The purge gas monitoring system A42 system is intended for use in Ex zone 2 or 22 and consists of the following individual components:

- Ex pzc controller type A42-M2 with integrated A42-I2 control unit
- Pressure switch type A42-P1
- Purge valve type A42-M6 (digital)
- or purge valve A41-M7 (proportional)
- Pressure reducing unit with pressure maintenance nozzle (for Ex zone 22 only)
- Pressure reducing unit A41-P6 for purge valves
- Pressurized Ex pzc control cabinet

Selection table for zone 2 and 22 applications

Components	Zone 2				Zone 22
	Free internal volume of control cabinet				
	0-300 litres	300-600 litres	600-1200 litres	Up to 1200 litres	0-4000 litres
Controller type A42-M2 0-25 mbar	1	1	1	1	1
Pressure switch type A42-P1 0-25 mbar	1	1	2	3	1
Purge valve type A42-M6 nozzle 2.5 mm	1				
Purge valve type A42-M6 nozzle 4.0 mm		1			
Purge valve type A42-M6 nozzle 5.5 mm			1		
Purge valve type A42-M6 nozzle 7.0 mm				1	
Pressure reducing unit type A41-P6 connection R1/4"	1	1			
Pressure reducing unit type A41-P6 connection R1/2"			1	1	
Pressure reducing unit type A41-P7 with pressure maintenance nozzle					1

Mounting example for Ex zone 2 (Explosive gas)

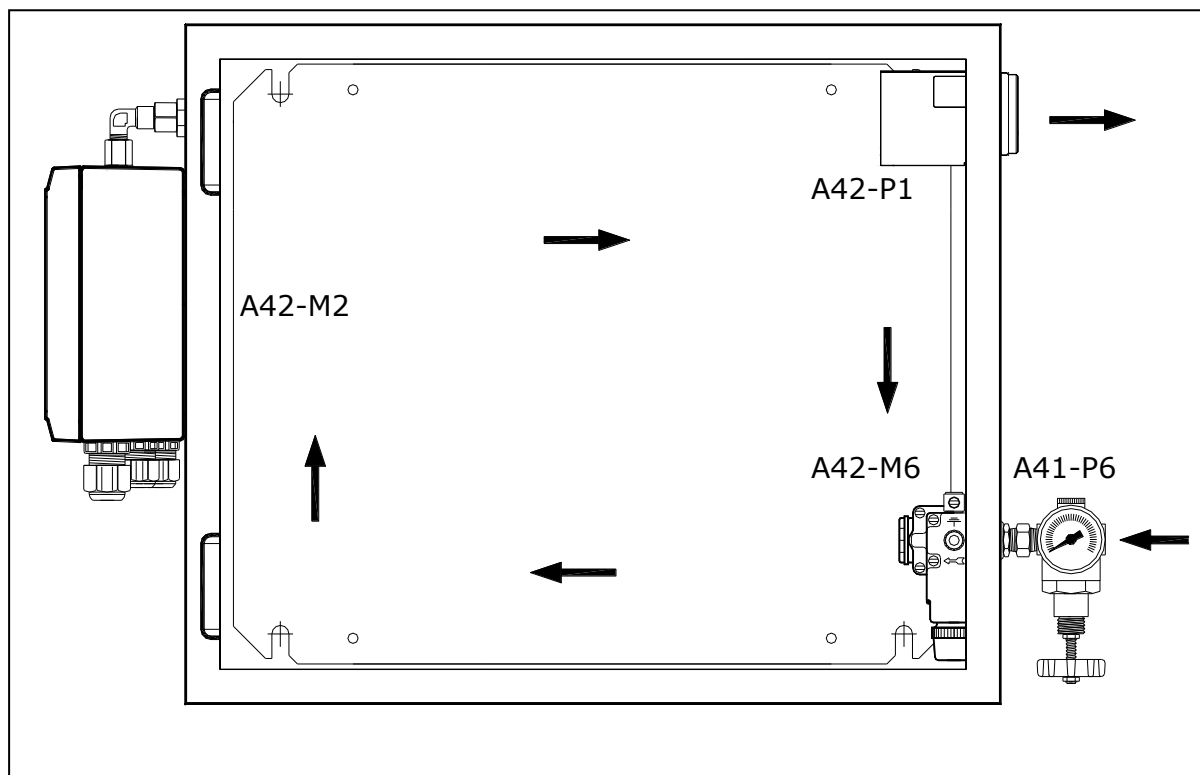

Mounting example for Ex zone 22 (Explosive dust)

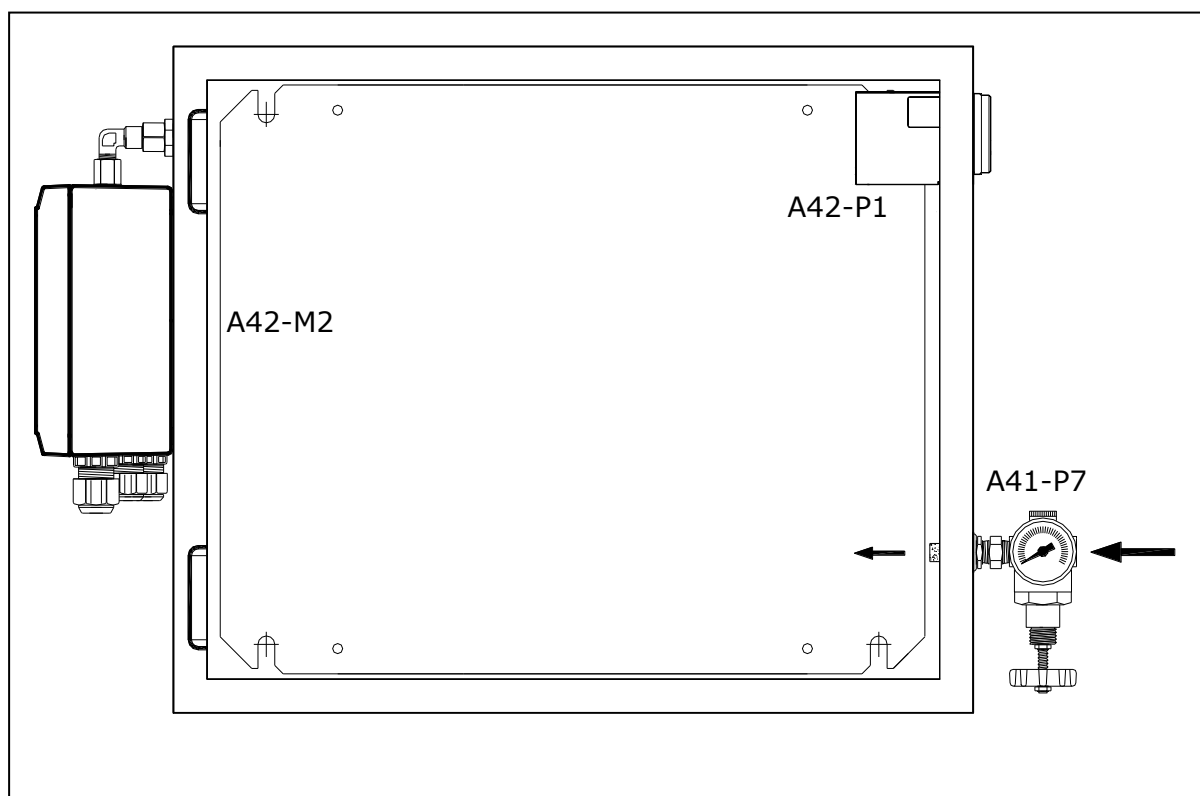

6 Leo Controller Type A42-M2 with Integrated Control Unit A41-I2

6.1 Functioning

The Leo controller type A42-M2 is an independent device and is equipped with all pressure sensors, relays, and time registration components required for the ignition protection type “pressurized enclosure” according to EIN EN 60079-2.

In combination with at least one pressure switch type A42-P1 and at least one purge valve type A42-M6 or type A42-M7 the Leo controller type A42-M2 controls and monitors the purge gas volume during the pre-purge period and the internal pressure of the Ex px control cabinet during operation through time-controlled conversion of the pneumatic signals of the pressure switch to electrical signals and control of the output relays K1 to K3 and A1 for connection of purge valves and the non-explosion-proof electrical built-in devices.

Intrinsic safe signal circuits for temperature switch, bypass key switch or external reset switch can be connected to the Ex i terminals provided for that purpose.

Selector switches for setting of purge times, pressure values, and function modifications and buttons for changing pressure values are provided within the control unit type A41-I2. The remaining purge time and the pressure values are indicated on the display. The control unit is plugged into the Leo controller and secured by 4 screws. Use of the Leo controller type A42-M2 without the control unit type A41-I2 is possible after configuration has been completed. Modification or configuration or display of the remaining purge time will not be possible anymore.

6.2 View

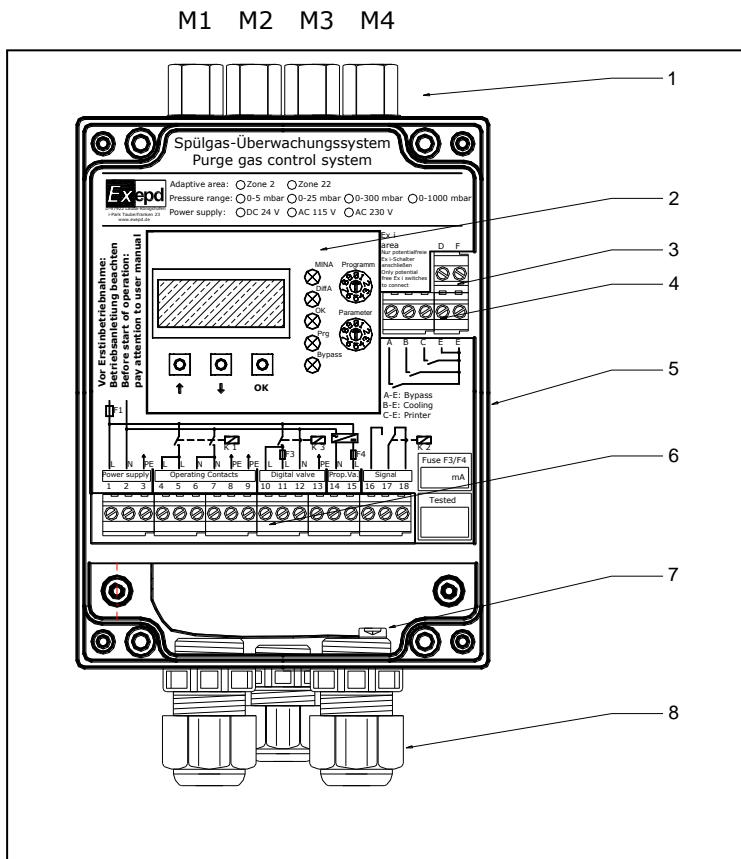



- 1: Measurements fittings
M1 ... M4
- 2: Integrated control unit
- 3: Ex i link to adjustment
- 4: Ex I terminals
- 5: Protection enclosure
- 6: Ex e terminals
- 7: Equipotent screw
- 8: Ex e cable glands

Measurements fittings:

- M1: Connctcion
inside pressure
Ex pz control cabinet
- M2: Connctcion
Atmosphere
- M3: 2. redundant Connctcion
Atmosphere
- M4: 2. redundant Connctcion
inside pressure
Ex pz control cabinet

6.3 Technical Specifications:

Type:	A42-M2
Marking:	 II 3G Ex nAC [ic] [pz] IIC T4 Gc  II 3D Ex tc [ic] [pzc] IIIC T80°C Dc
Mains voltage:	AC 230V ($\pm 10\%$); 50-60 Hz Option: AC 115V ($\pm 10\%$); 50-60 Hz Option: DC 24V ($\pm 10\%$)
Pressure range:	0-25 mbar
Measurement connections:	M1 and M4; female thread R 1/8" M2 and M4; atmospheric connection
Purge time:	adjustable from 0-99 min
Purge valve outlet K3:	Terminals 10 till 13
Valve protection for AC 230 V:	F3: 80mA F4: 80 mA (for 7-9 Watt valves) F3: 160 mA F4: 160 mA (for 15 Watt valves)
Valve protection for DC 24V:	F3: 500 mA F4: 500 mA (for 7-9 Watt valves) F3: 1000 mA F4: 1000 mA (for 15 Watt valves)
Release relay K1:	Terminals 4 till 9 Switching capacity maximum 5 A
Signal relay K2:	Terminals 16 till 18
Terminal clamps:	maximum 2.5 mm ²
Cable entries:	2 x M20x1.5 mm and 2 x M16x1,5 mm (Standard)
Admissible ambient temperature:	-20°C ... +60°C
Enclosure material:	Powder-coated aluminium (Mg smaller 6%)
IP Degree:	
According EN 60529	IP66
According EN 60079-0/31	IP 64 tested
Weight:	3 kg
Dimensions:	see annex
Mounting holes:	see annex

6.4 Circuit Diagram

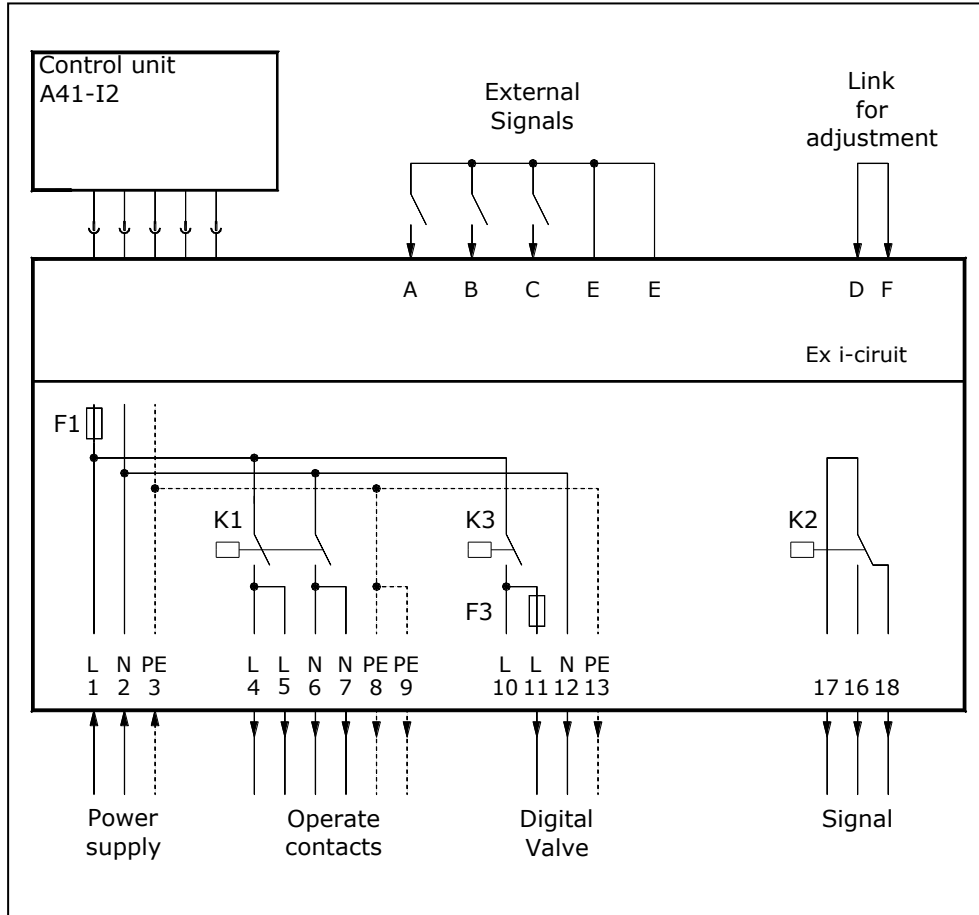

Default programming of potential-free Ex -i contacts:

- A-E Bypass
- B-E Cooling (The purge valve opens if the jumper is connected)
- C-E Cooling (purge valve will be activated for cooling purposes if terminal is bridged)
- D-F Link for adjustment

7 Pressure Switch Type A42-P1 for Ex px Control Cabinets

7.1 Functioning

The pressure switch type A42-P1 is used as purge gas outlet of control cabinets in the ignition protection type "pressurized enclosure". It consists of the pressure relief valve, measuring orifice, sparking barriers. The type A42-P1 pressure switch is mounted either on the Ex pzc control cabinet or inside it. The pressure switch is attached to the Ex pzc control cabinet by using the supplied sealing. Ensure that the supplied sealing is positioned on the outside.

7.2 View

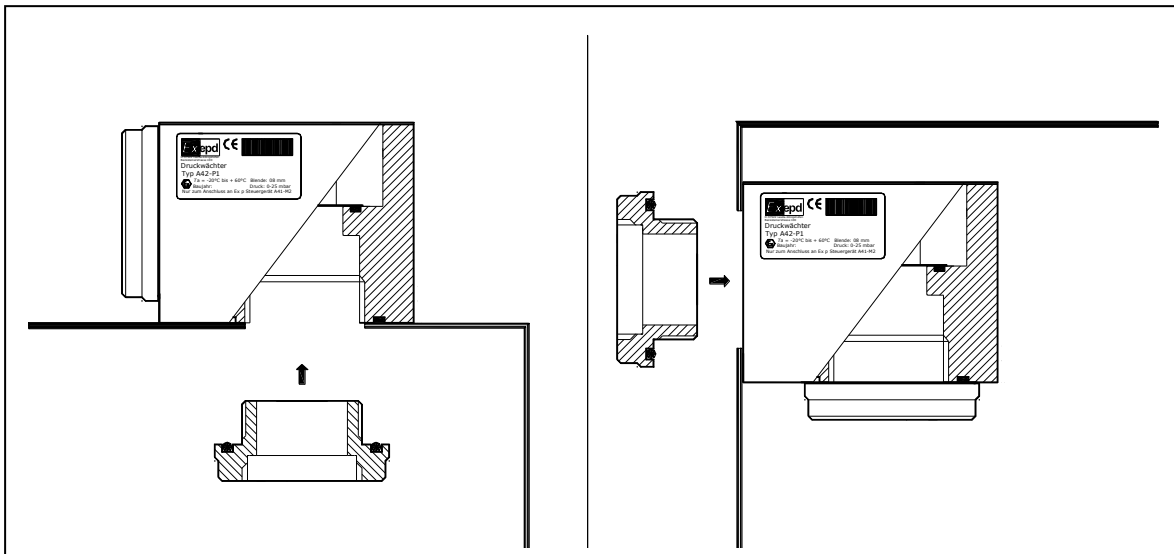

7.3 Technical Specifications

Pressure switch type A42-P1:	only in combination with Ex pzc controller type A42-M2
Purge gas flow rate:	see chapter purge time calculation
Maximum cabinet thickness:	5.0 mm
Pressure range:	0-25 mbar
Opening pressure:	ca. 4 mbar
Weight:	210 g
Material:	PP light grey

8 Purge Valve Type A42-M6 (Digital Technology)

8.1 Functioning

Type A42-M6 purge valves are used for control of the purge gas during the pre-purge stage and for control of the leakage volume during operation. The purge valves can be mounted outside or inside the Ex px control cabinet. The protection of the maximum flow volume for the explosive-proof control coils is realized by the integrated protections of the Leo controller type A42-M2. The purge valves are supplied with different purge air nozzles. The dimensioning of the purge air nozzle is subject to the volume of the connected Ex px control cabinet and the available purge gas pressure.

The table below is to be used as an aid to dimensioning:

Selection of the purge air nozzle depending on the number of pressure switches used

Internal volume of the Ex px control cabinet	1 pressure switch purge gas pressure 2 to 3 bar	2 pressure switches purge gas pressure 2 to 3 bar	3 pressure switches purge gas pressure 2 to 3 bar
Up to 300 litres	Ø 2.5 mm	--	--
300 to 600 litres	Ø 4.0 mm	Ø 4.0 mm	--
600 to 1200 litres	Ø 4.0 mm	Ø 5.5 mm	Ø 5.5 mm
From 1200 litres	Ø 4.0 mm	Ø 5.5 mm	Ø 7.0 mm

8.2 View

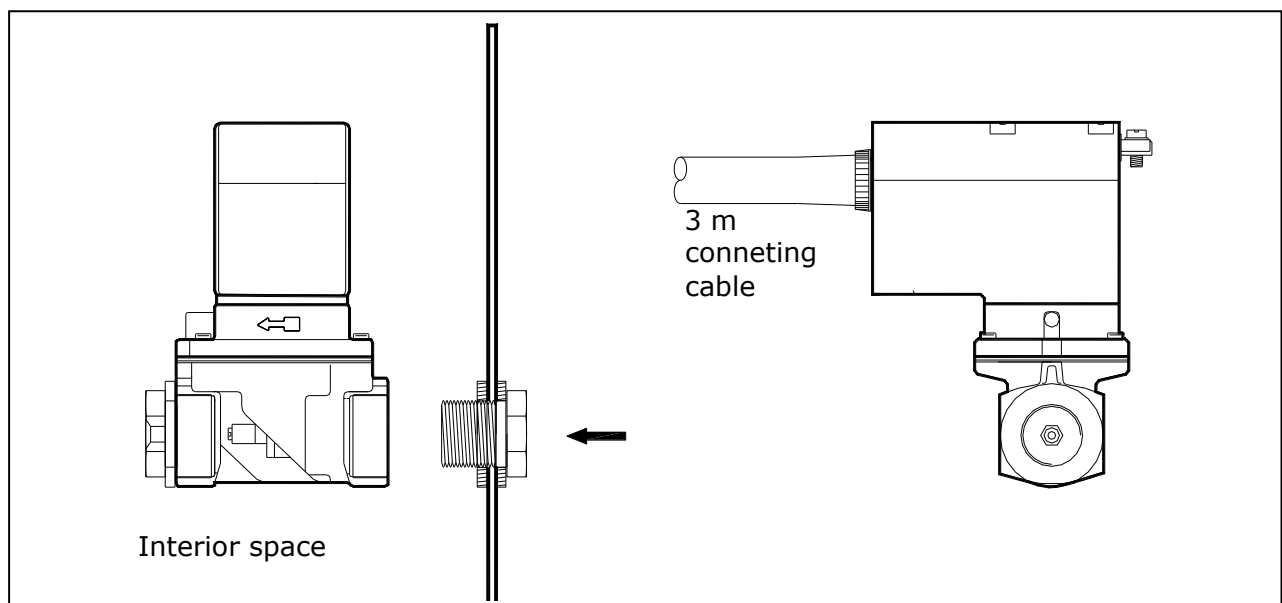

9 Control unit of controller A42-M2

After mounting of all Ex p components on the Ex pzc control cabinet the control unit type A41-I2 can be used for setting the Ex pzc system type A42 system.

Note:

To avoid operating errors modifications can only be made after connection of a bridge to the Ex i terminals D-F.

The setting and signalling is made through the main operation components:

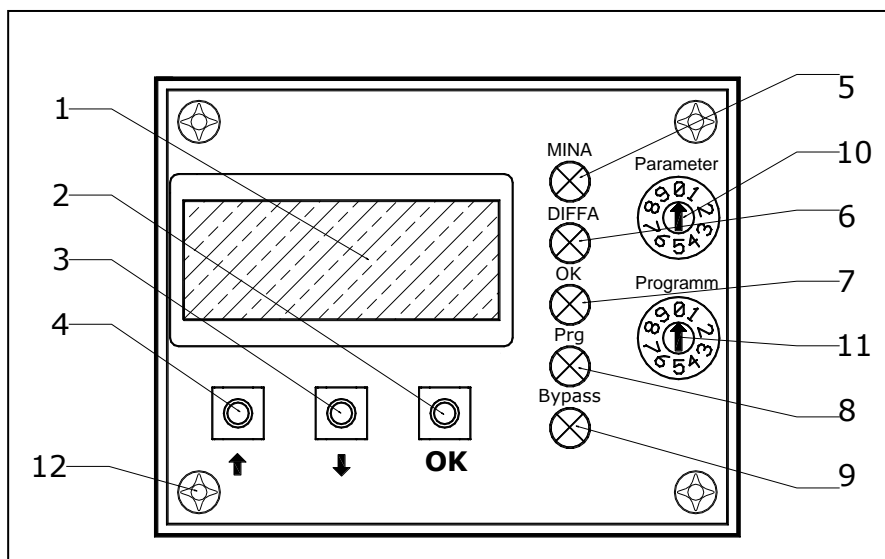

- | | |
|------------------|---|
| 1: Display | Shows the residual parameter |
| 2: Button (OK) | Press once to confirm and save a changed value.
If not pressed and mains supply is not disconnected changed value will not be saved. |
| 3: Button (↑) | Press to decrease displayed value by one counter. |
| 4: Button (↓) | Press to increase displayed value by one counter. |
| 5: LED (MIN) | Illuminated if internal pressure exceeded the value of MIN. |
| 6: LED (MXP) | Illuminated if the purge pressure exceeded the value of MXP. |
| 7: LED (Operate) | Illuminated if the release was made by relay K1. |
| 8: LED (Purge) | Illuminated during pre-purge time countdown. |
| 9: LED (Bypass) | Flashes if bypass key switch is activated. |
| 10: Selection | BCD switch is used to determine the parameter to be shown on the display. |
| 11: Parameter | Use this BCD switch to display individual parameters of a selection. |
| 12: Screws | Use only M3x20mm screws |

9.1 BCD switch Program

The lower rotary switch is needed to choose the display programs

Pos. 0:	At this position the actual value of rotary switch Parameter be displayed always
Pos. 1:	At this position the set value of rotary switch Parameter be displayed and can be modify (Attention: Modification of set values is only possible with the link D-F)
Pos. 2:	Same as Pos. 0
Pos. 3:	Display of general Information
Pos. 4-9.	Same as Pos. 0

9.2 BCD switch Parameter (Program auf Pos. 0)

The upper rotary switch Parameter is needed to display the values, if the lower rotary switch **Program** is set to position 0.

Pos. 0-9:	Display of the program sequence
-----------	---------------------------------

9.3 BCD switch Parameter (Program on Pos. 1)

Pos. 1:	Switch value of MIN
Pos. 2:	Switch value of DP
Pos. 3:	Switch value of MXP
Pos. 4:	Switch value of MAX
Pos. 5:	Selection of the purge program
Pos. 6:	Adjustment of the purge time
Pos. 7:	Adjustment of relay K2
Pos. 8:	Adjustment of the general time delay
Pos. 9:	Continuously display of the inside pressure

Function in detail:

9.3.1 Switching value of MIN:

If the inside pressure fall below the value of MIN, the relay K1 switch in reference of the configuration of K1.

9.3.2 Switching value of DP

If the inside pressure fall below the value of DP, the purge valve switch on for the period of low pressure

9.3.3 Switching value of MXP

If the inside pressure reaches the value of MXP, the purge time started.

9.3.4 Switching value of MAX

If the inside pressure fall below the value of MIN, the relay K1 switch in reference of the configuration of the purge program.

9.3.5 Purge program

Different purge programs are integrated into the Leo controller. With these programs special requirements available to choose for Ex pzc purge monitoring systems.

- DUST 22: With this adjustment a connected purge valves not activated the output 10-11 is free voltage continuously.
Relay K1 doesn't switch off, if the inside pressure fall below the value of MIN during operate.
Relay K1 switches off, if the inside pressure reaches the value of MAX.
- PURGE Normal program
Purge valve switch on directly.
Purge valve switch on, if the inside pressure fall below the value of DP.
Relay K1 doesn't switch off, if the inside pressure fall below the value of MIN during operate.
Relay K1 switches off, if the inside pressure reaches the value of MAX.
- PURGE A Purge valve switch on, if the inside pressure reaches the value of MIN.
Purge valve switches on, if the inside pressure fall below the value of DP during operate.
Purge valve switches off, if the inside pressure fall below the value of MIN during operate
Relay K1 doesn't switch off, if the inside pressure fall below the value of MIN during operate.
Relay K1 switches off, if the inside pressure reaches the value of MAX.
- PURGE B Purge valve switch on, if the inside pressure reaches the value of MIN.
Purge valve switches on, if the inside pressure fall below the value of DP during operate.
Purge valve switches off, if the inside pressure fall below the value of MIN during operate
Relay K1 switches off, if the inside pressure fall below the value of MIN during operate.
Relay K1 switches off, if the inside pressure reaches the value of MAX.
- PURGE C up to E Same function as PURGE A

9.3.5.1 Sequence table of the different programs

Program	Power supply ON	Inside pressure higher than MIN	Inside pressure higher than MXP	Inside pressure between MIN and MAX Operate	Inside pressure Higher than MAX	Inside pressure lower than DP	Inside pressure lower than MIN
DUST 22	Purge valve OFF	Purge valve OFF	Purge Time not active	Operate relay K1 ON	Operate relay K1 OFF	Purge valve OFF	Operate relay K1 ON
Purge	Purge valve ON	Purge valve ON	Purge time active	Operate relay K1 ON	Operate relay K1 OFF	Purge valve ON	Operate relay K1 ON
Purge A	Purge valve OFF	Purge valve ON	Purge time active	Operate relay K1 ON	Operate relay K1 OFF	Purge valve ON	Operate relay K1 ON
Purge B	Purge valve OFF	Purge valve ON	Purge time active	Operate relay K1 ON	Operate relay K1 OFF	Purge valve ON	Operate relay K1 OFF
Purge C-E	Purge valve OFF	Purge valve ON	Purge time active	Operate relay K1 ON	Operate relay K1 OFF	Purge valve ON	Operate relay K1 ON

9.3.6 Adjustment of the purge time

The switches (↑), (↓) and (OK) are needed to adjust the purge time

9.3.7 Time delay

The switches (↑), (↓) and (OK) are needed to adjust the time delay

9.3.8 Signal relay

The Relay K2 is used as a signal relay and can be programmable. Therefore the following possibilities exist:

- Signal relay K2 switches at the same as K1
- Signal relay K2 switches if the value of MIN exceeded
- Signal relay K2 switches if the value of MIN fall below
- Signal relay K2 switches if the value of DP exceeded
- Signal relay K2 switches if the value of DP fall below
- Signal relay K2 switches if the value of MXP exceeded
- Signal relay K2 switches if the value of MAX exceeded
- Signal relay K2 switches if the purge time is activated
- Signal relay K2 switches if the bypass key switch is activated
- Signal relay K2 switches if an internal alarm existed

9.4 Rotary switch "Parameter" (Program on Pos. 3)

The rotary switch "Parameter" is used to select different information, if the rotary switch "Program" is set to Pos. 3.

- | | |
|---------|---------------------------------------|
| Pos. 1: | Display the internal panel pressure |
| Pos. 2: | Information of the serial number |
| Pos. 3: | Information of the purge nozzle |
| Pos. 4: | Information of the orifice |
| Pos. 5: | Information purge volume of the panel |
| Pos. 6: | Information of the installed language |
| Pos. 7: | Display the internal panel pressure |
| Pos. 8: | Display the internal panel pressure |
| Pos. 9: | Display the internal panel pressure |

Note to the other Positions:

All other positions of the rotary switch are not used.

10 Purge Time Calculations (Ex Zone 2)

The following diagram shows the differential pressure in dependence on the measuring orifice of the pressure switch.

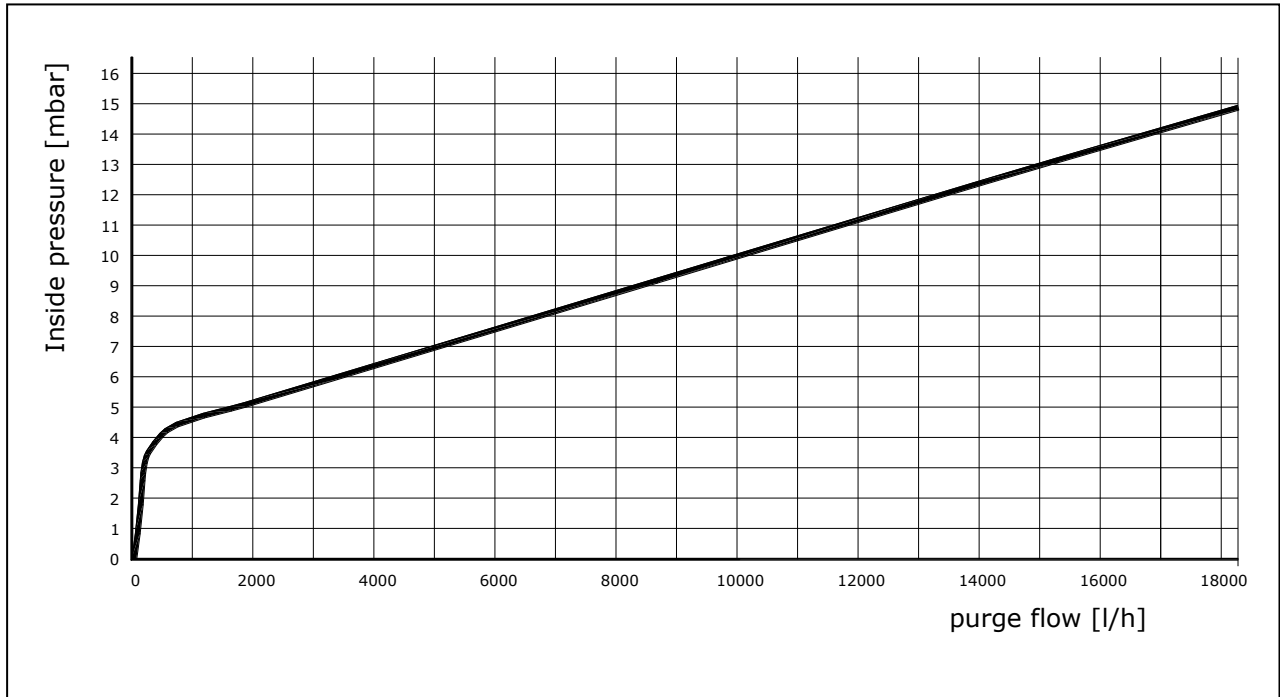

Example 1:

Number of pressure switches: 1
Inside pressure MXP: 12 mbar
Volume of enclosure: 400 litres
Purge volume: 5 times
Resulting flow volume according to diagram: 12500 l/h

Resulting purge time: $\frac{400 \text{ litres} \times 5 \text{ times}}{12500} \times 60 \text{ minutes} = 9,6 \text{ minutes}$

Example 2:

Number of pressure switches: 2 (3)
Inside pressure MXP: 12 mbar
Volume of enclosure: 400 litres
Purge volume: 5 times
Resulting flow volume according to diagram: 12500 l/h

Resulting purge time: $\frac{400 \text{ litres} \times 10 \text{ times}}{12500 \times 2 (3)} \times 60 \text{ minutes} = 4,8 (3,2) \text{ minutes}$

11 Operation, Maintenance and Troubleshooting

The operator of an electrical plant in explosive atmosphere must maintain the operating devices in proper condition operate and monitor them properly and perform necessary maintenance and repair works. Also see EN 60079-17.

Maintenance and fault removal works must be left to qualified and trained staff.

The given safety regulations must be observed for all maintenance and/or fault removal works. All warning indications on the operating devices must be observed!

For maintenance and fault removal works only original parts are to be used subject to prior agreement of the manufacturer.

The applicable legal regulations and directives must be observed prior to recommissioning.

12 Order Numbers

The models, pressure ranges, etc. are given in plain text, if deferring from the standard options specified below. The supply voltage will be specified in any case.

Controller type A42-M2
Pressure range 0-25 mbar

230V AC Article No 400062
24V DC Article No 400013

Control unit type A41-I2

Article No 400020

Pressure switch type A42-P1
Pressure range 0-25 mbar
Opening pressure ca. 4 mbar

Article No 400011

Further products on request:

Purge valve, digital
Purging air nozzle
Pressure station includes manometer
Ex switch contactor
Ex terminal box

Ex pzc control cabinets A32-P * - *****
Complete system on request.

13 Dimensions:

13.1 Controller A42-M2

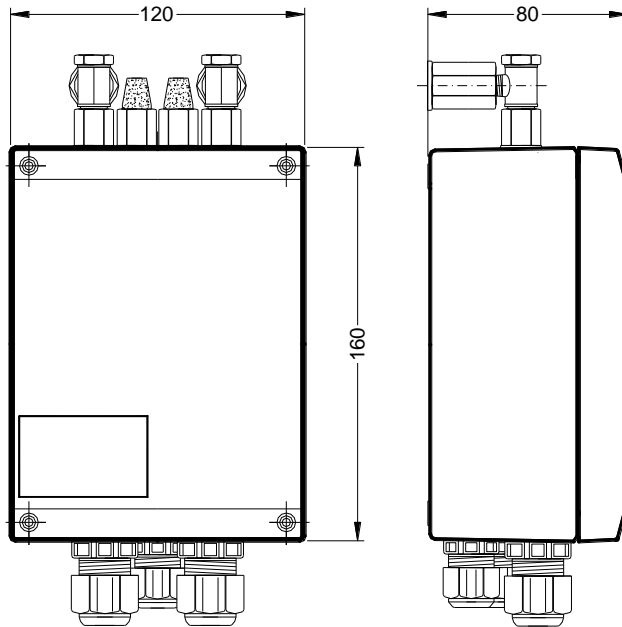

Dimension of mounting (4 x M4): 83x145 mm

13.2 Pressure monitor A42-P1

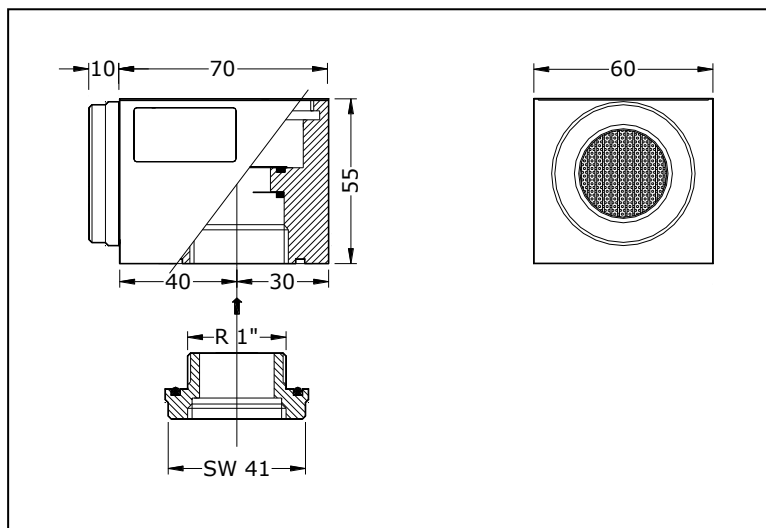

Dimension of mounting: 1x \varnothing 36mm

13.3 External control unit

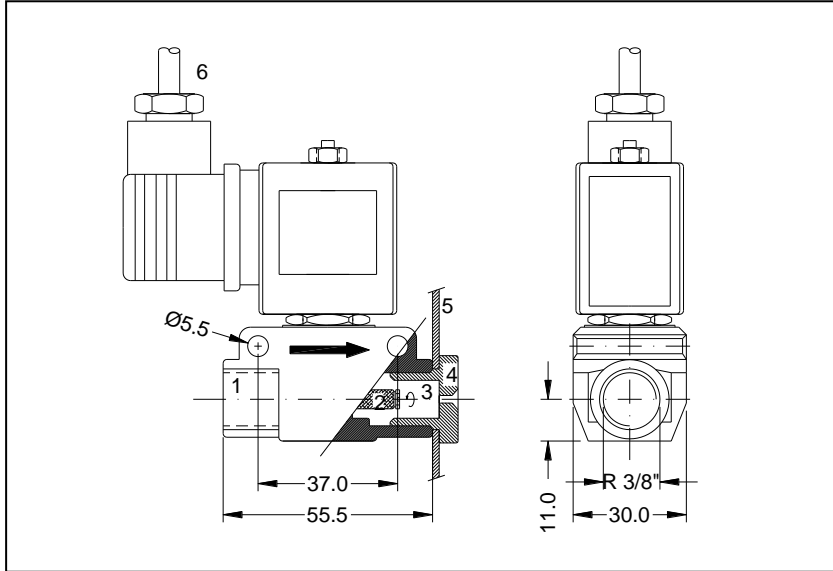

- 1: Purge inlet R 3/8"
- 2: Needle valve; Leakage
- 3: Adjustment screw
- 4: Purge nozzle
- 5: Ex pz enclosure
- 6: power supply cable
3x0,75mm² / 3 m

Dimension of mounting: 2 x M4 / 36x86 mm

13.4 Pressure regulator A42-P6

Connection G1/4"

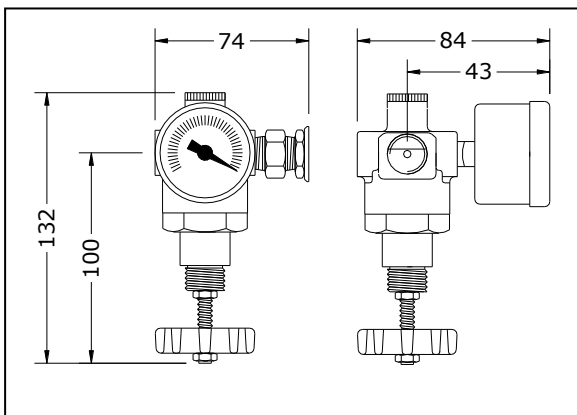

Connection G1/2"

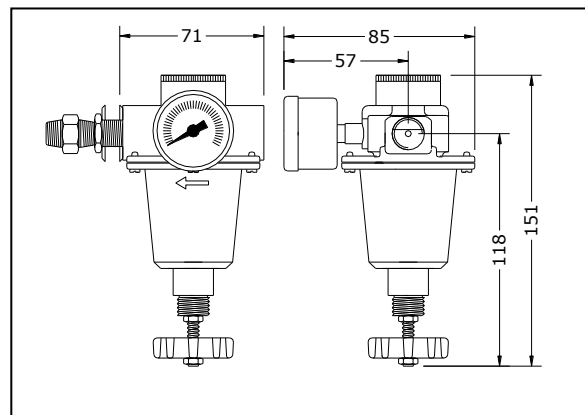

14 Test certificate of Leo 2 Controller type A42-M2

		Factory setting	Ex pzc System Einstellwerte
1	Type		
2	Power supply	---	Volt
3	Serial- Nr.	---	
4	Temperature class	T4 / 80°C	
5	Range of surrounding temperature	-20°C up to +60°C	
6	Switch off value MIN between panel and Atmosphere	1,0 mbar	mbar
7	Operate pressure DP during operate	1,5 mbar	mbar
8	Minimum purge pressure MXP during purge time	7,5 mbar	mbar
9	Switch off value MAX between panel and Atmosphere	12 mbar	mbar
10	Purge program	Purge_B	
11	Purge time	12' 00"	
12	Function of K2	Switches as the same as K1	Switches as the same as:
13	Time delay	5"	Seconds
14	Purge valve; function	Digital	Digital

Test engineer

(Name)	Date:	Signature and sign

EU-Konformitätserklärung
EU Declaration of Conformity



Dokument A42-M2-C0001-8

Hersteller/Manufacturer:

Exepd GmbH, i_PARK TAUBERFRANKEN 23, D-97922 Lauda-Königshofen

Gegenstand der Erklärung/Object of the declaration:*

Ex pz/pD Steuergerät Typ A42-M2
Ex pz/pD Controller type A42-M2
(400013, 400062)

Der oben beschriebene Gegenstand der Erklärung erfüllt die einschlägigen Harmonisierungsvorschriften der Union/The object of the declaration described above is in conformity with the relevant Union harmonisation legislation:

2014/34/EU (-ABI. L 96 / 29.03.2014-)

Die Anwendung der folgenden einschlägigen harmonisierten Normen oder technischen Spezifikationen wurde als hilfreich erachtet, ganz oder teilweise die Konformität mit den wesentlichen Anforderungen zu erfüllen/The use of the following relevant harmonised standards or references to other technical specifications were helpfully, to fulfil totally or partly the conformity with the requirements:

EN IEC 60079-0:2018;
EN 60079-2:2014/AC2015 (IEC 60079-2:2014 + Cor.: 2015);
EN 60079-11:2012 (IEC 60079-11 :2011 + Cor.:2012);
EN 60079-31:2014 (IEC 60079-31:2013);
EN 60079-15:2010 (IEC 60079-15:2010)

Kennzeichnung und Hauptzündschutzart/Marking and main type of protection:*

Ex nAC [ic] [pzc] IIC T4 Gc Ex tc [ic] [pzc] IIIC T80°C Dc

Ex II 3 G/D

CE

Qualitätssicherung Produktion gemäß/Production quality system according:

2014/34/EU

Die alleinige Verantwortung für die Ausstellung dieser Konformitätserklärung trägt der Hersteller/This declaration of conformity is issued under the sole responsibility of the manufacturer.

Lauda-Königshofen, den 06.07.2021

Stefan Höger, GF/CEO, Exepd GmbH

*Die vollständige Produktbeschreibung und verwendete Zündschutzprinzipien sind in der zugehörigen Artikelbeschreibung zur Artikelnummer beschrieben (-> Auftragsdokumentation)
The product and used protection principles are described in the relevant article description according the article number (-> order documents)

Exepd GmbH
i_Park Tauberfranken 23
97922 Lauda-Königshofen